

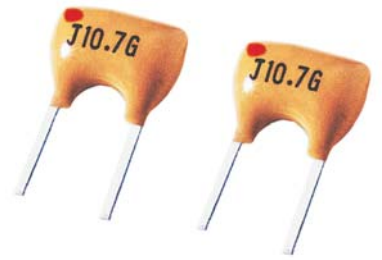

# JT10.7 Series For FM

## SCOPE

JT10.7M for FM are resonated devices that offer adjustment free audio detection in both wide and narrow bandwidths. These IC dependent devices utilize FM specific detection methods to convert changes in frequency into an intelligible audio signal.



## TECHNICAL CHARACTERISTICS

Part Number	Demodulation Output at fo (mv) min	Distortion Factor at fo (%) max	Demodulation 3 dB Band Width (Khz) max	Applicable IC
JT10.7MG1	25	1.0	345	CX-2009,CX-20111
JT10.7MG3	650	1.0	±150	TA7303P,TA7130, PC1028H,LA1150
JT10.7MG16	60~90	0.9	300	TA8122AN
JT10.7MG18	60~90	0.9	300	TA8132N
JT10.7MG33	45	0.7	250	TA2007
JT10.7MG80	65	1.0	300	TA2104AFN
JT10.7MG82	90	0.8	320	TA2099N
JT10.7MG92	60	1.0	300	TA2132P
JT10.7MC1	35	1.0	242	CXA1019M,CX-20091

## TEST CIRCUIT

### JT10.7MG3

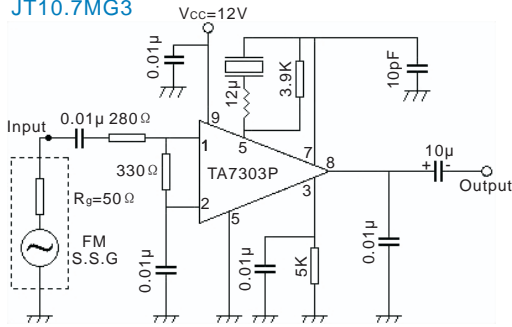

### JT10.7MG16

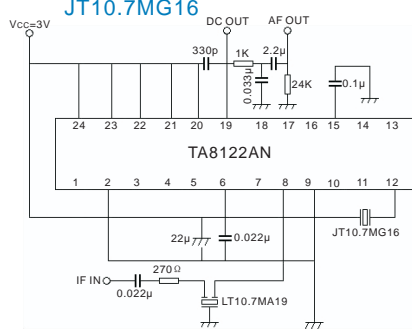

### JT10.7MG18

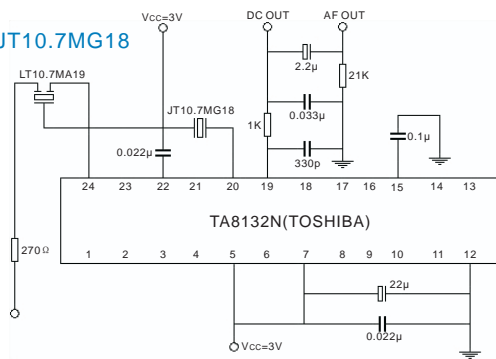

### JT10.7MC1

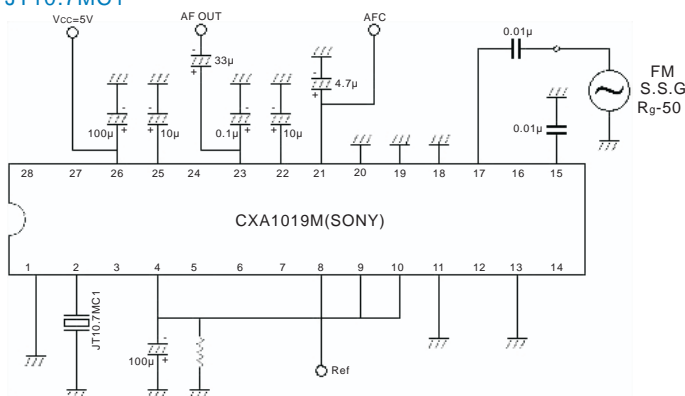

## STANDARD RULE

Center Frequency	Color
D:10.64MHz±30KHz	Black
B:10.67MHz±30KHz	Blue
A:10.70MHz±30KHz	Red
C:10.73MHz±30KHz	Orange
E:10.76MHz±30KHz	White

## DIMENSIONS

